

FUNCTIONAL DESCRIPTION

Machining generates oil mist and coolant vapor that can affect operator health, reduce efficiency, and accelerate machine wear. An oil mist collector removes airborne contaminants, improving the working environment and extending equipment service life.



APPLICATION

The oil mist collector is used to purify and recycle the oil mist generated by various processing equipment. It has a wide range of applications and is suitable for fully enclosed and semi-enclosed processing equipment, such as CNC numerical control equipment, gear processing equipment, and is especially suitable for metal processing, sheet metal processing and welding, mold manufacturing, automotive parts manufacturing, fasteners production, and other manufacturing industry equipment.

STRUCTURAL FEATURES

Mechanical-type structure with multi-stage filtration effectively captures and recovers oil mist, achieving over 99% collection efficiency under standard test conditions and maintaining high efficiency across varying concentrations.

Multi-stage filtration with progressively finer efficiency, compliant with JB/T 12907-2016.

Low noise design (≤ 75 dB(A)) for improved shop-floor conditions.

Compact, space-saving structure with flexible installation.

Simple design for easy installation and maintenance, reducing both initial investment and long-term operating costs.

Configurable filter combinations to suit different application requirements.

ADVANTAGES OF USE

- ◆ 1. Reduced impact on employees: Oil mist particles of 0.3 to 3.5 μm can remain in the body, posing a health hazard.
- ◆ 2. Reduce workplace accidents: Oil mist deposition makes the work area, floor, and walkways slippery and prone to fall accidents.
- ◆ 3. Reduce the damage to mechanical equipment: a large amount of oil mist generated by high-speed cutting for a long time adsorbed on the equipment and workpiece, may become the cause of mechanical equipment and electrical system failure. To the maintenance of machinery and equipment work to bring a lot of trouble, but also make the processing accuracy of machinery and equipment is greatly reduced.
- ◆ 4. Reduce the consumption of coolant: the recovered oil mist can be reused, reducing the expenditure of coolant for the factory.
- ◆ 5. Reduce damage to the environment and waste of resources: If the oil mist gas is discharged to the outdoor, it will damage the environment and cause waste of resources.

YWS2 SERIES

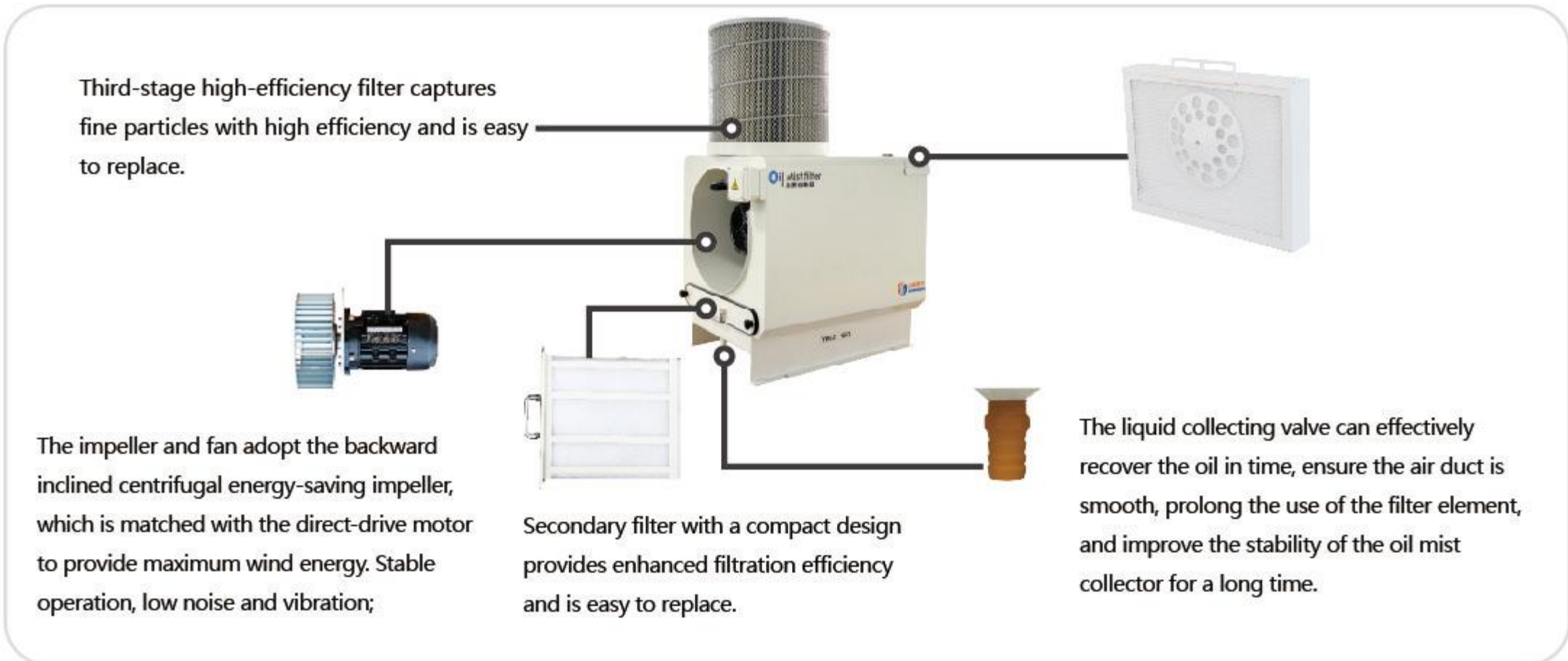

MODEL SELECTION METHOD

Recommended models are provided below based on typical applications and industry standards; final selection should be determined according to actual operating conditions.

For fully enclosed machines	Oil Mist Models	Inlet Diameter(mm)	Air Volume	Door openings and closings per minute, general value (times/minute)	Suitable for processing room volume(m ³)
	YWS2-55	Φ148	600	4~10	1~2.5
YWS2-75	Φ148	800	4~10	1.5~3.5	
YWS2-150	Φ148	1000-1300	4~10	3~5	
YWS2-150A	Φ198	1300-1500	4~10	4~6	
YWS2-220	Φ148	1500-1800	4~10	5~7	
YWS2-220A	Φ198	1800-2100	4~10	7~10	
General Formula		Airflow = Volume*Opening Frequency*60			

For partially enclosed machines	Oil Mist Models	Inlet Diameter(mm)	Air Volume	Estimated air speed required to absorb oil mist, general value(m/s)	Suitable for the opening area of the processing room(m ²)
	YWS2-55	Φ148	600	0.5<V<1	0.3~0.6
YWS2-75	Φ148	800	0.5<V<1	0.4~0.8	
YWS2-150	Φ148	1000-1300	0.5<V<1	0.5~1.0	
YWS2-150A	Φ198	1300-1500	0.5<V<1	0.6~1.2	
YWS2-220	Φ148	1500-1800	0.5<V<1	0.9~1.8	
YWS2-220A	Φ198	1800-2100	0.5<V<1	1.1~2.2	
General Formula		Air volume = open area * estimated wind speed * 3600			

MODEL DESCRIPTION

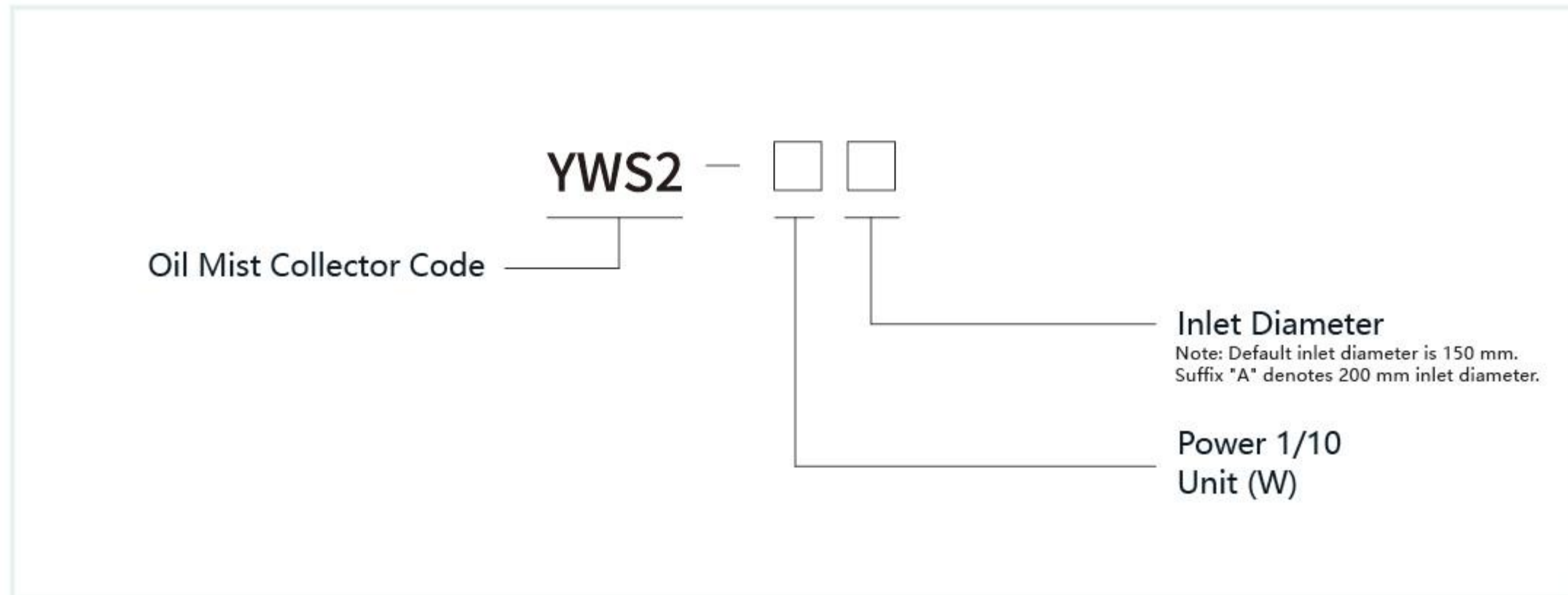

PRODUCT PARAMETERS

Model No.	YWS2-55	YWS2-75	YWS2-150	YWS2-150A	YWS2-220	YWS2-220A
Power supply	3-phase, 220V/380V	3-phase, 220V/380V	3-phase, 220V/380V	3-phase, 220V/380V	3-phase, 220V/380V	3-phase, 220V/380V
Power (kW)	0.55	0.75	1.5	1.5	2.2	2.2
Rotating speed (R.P.M)	2740	2840	2840	2840	2840	2840
Current (A)	2.33/1.35	3.06/1.77	5.77/3.33	5.77/3.33	8.15/4.72	8.15/4.72
Air Volume (m ³ /h)	600	800	1000-1300	1300-1500	1500-1800	1800-2100
Noise dB (A)	66±2	66±2	68±2	68±2	68±2	68±2
Efficiency (%)	99	99	99	99	99	99
Inlet Diameter (mm)	Φ148	Φ148	Φ148	Φ198	Φ148	Φ198
Diameter of Oil Return Port (mm)	16	16	16	16	16	16
Element Material	Synthetic Fiber	Synthetic Fiber	Synthetic Fiber	Synthetic Fiber	Synthetic Fiber	Synthetic Fiber
Dimensions (L × W × H) (mm, without three-stage cartridge and holder)	610 × 400 × 530	630 × 410 × 550	640 × 450 × 586	640 × 450 × 586	640 × 450 × 586	655 × 450 × 586
Power Cord	4-core	4-core	4-core	4-core	4-core	4-core
Color	RAL9010 Customizable	RAL9010 Customizable	RAL9010 Customizable	RAL9010 Customizable	RAL9010 Customizable	RAL9010 Customizable

Note: Customers with special requirements for products support customization.

OPTIONAL ACCESSORIES



INSTALLATION METHOD

Top Mounting as Shown

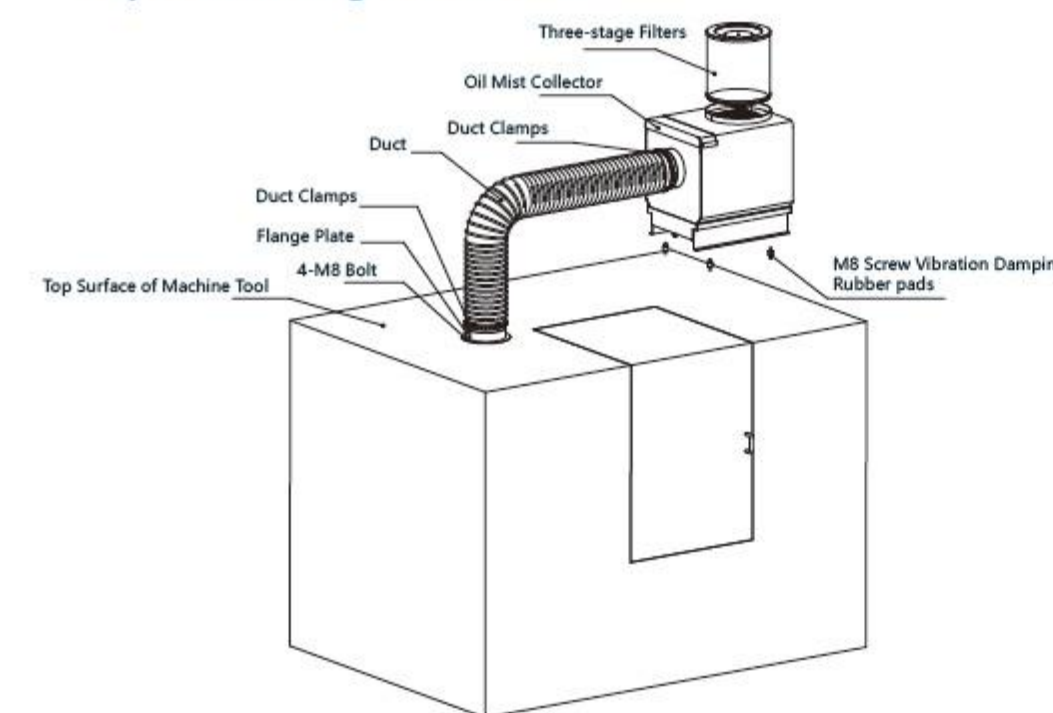

Top Mount

Side Mounting as Shown

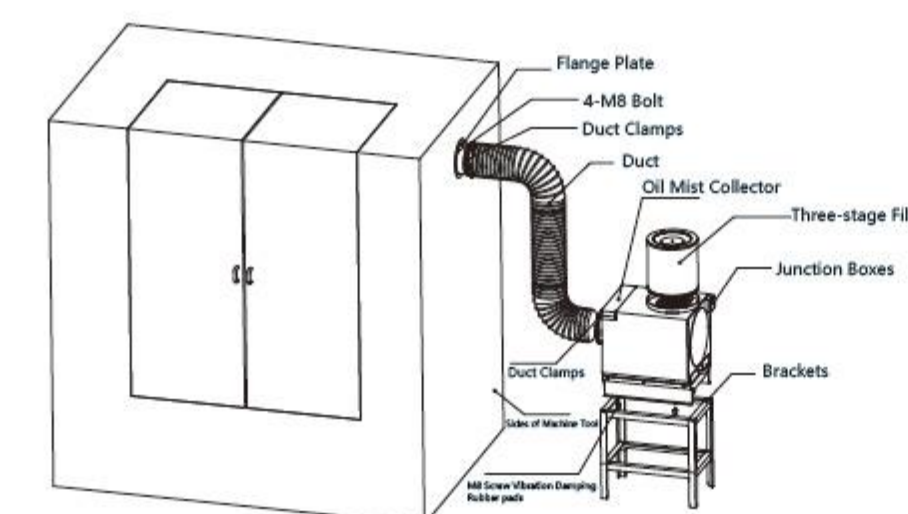

Side Mount

COLLECTION METHOD

**CENTRIFUGAL AGGREGATION,
RETURN PIPE RETURN**

STRUCTURAL FEATURES

- Oil mist collector adopts mechanical centrifugal structure, using porous centrifugal impeller collision, fine filter cotton cohesion on the effective collection and recovery of oil mist, the collection rate of more than 99%, and for different concentrations of oil mist All have excellent recycling efficiency.
- High working efficiency, high filtration precision, effective collection and recycling.
- The equipment is stable and reliable, and complies with the industry standard JB/T12907-2016.
- Low upfront investment and post maintenance costs.
- Low noise design to improve the quality of workshop working environment.
- Scientific design, simple structure, easy to install and maintain.



ADVANTAGES

- Reduce the impact on employees: 0.3-3.5um oil mist particles are inhaled and difficult to expel, jeopardizing health.
- Reduces workplace accidents: Oil mist deposits make work areas and floors slippery and prone to fall accidents.
- Reduced damage to machinery and equipment: oil mist adsorbed on equipment and workpieces for long periods of time can lead to mechanical and electrical system failures. Obstacles. Affects the work of mechanical equipment and reduces the machining accuracy of mechanical equipment.
- Reduce the consumption of coolant: the recovered oil can be reused, reducing the cost of the enterprise.
- Reduces environmental damage and resource waste: Oil mist discharged into the air damages the environment and also causes resource waste.
- Reduces environmental damage and resource waste: Oil mist discharged into the air damages the environment and also causes resource waste.

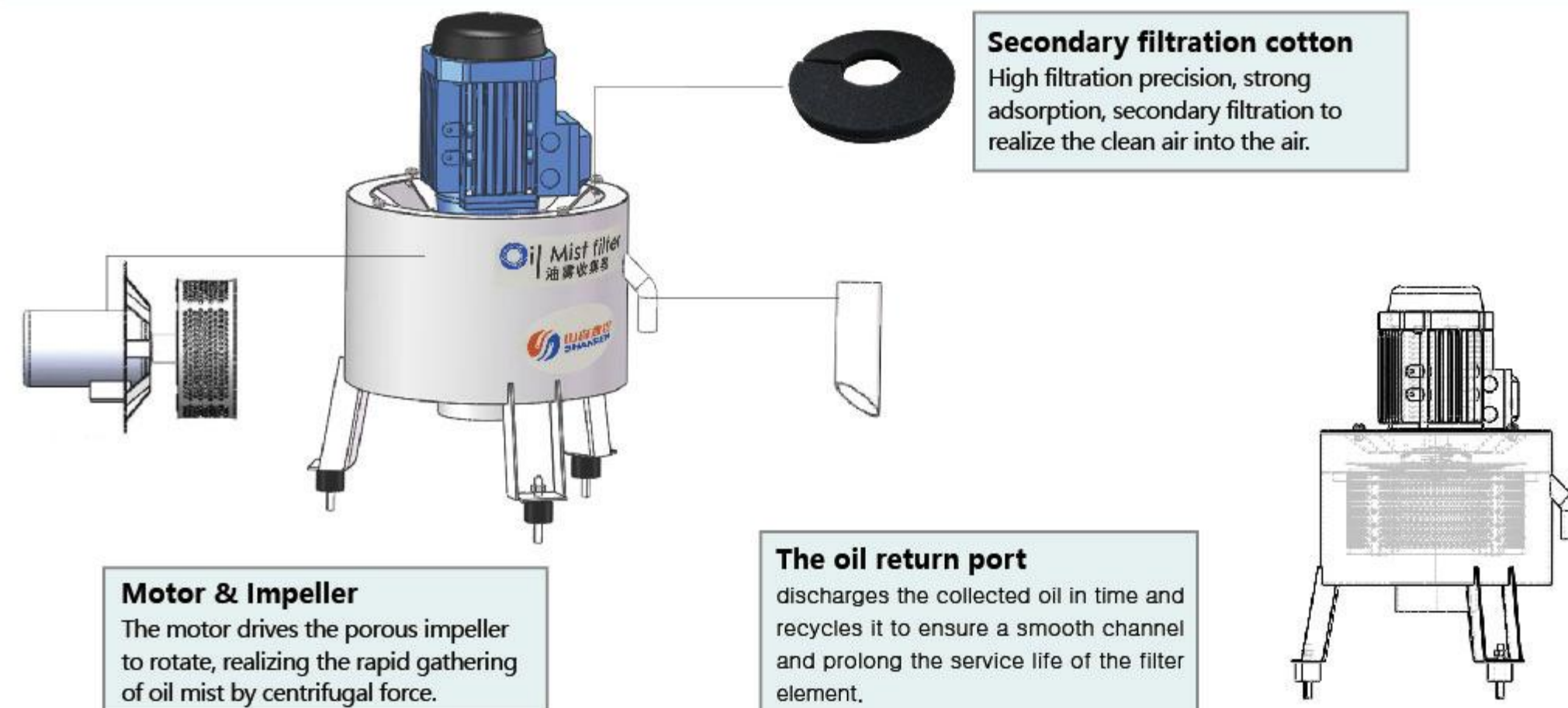

MODEL DESCRIPTION

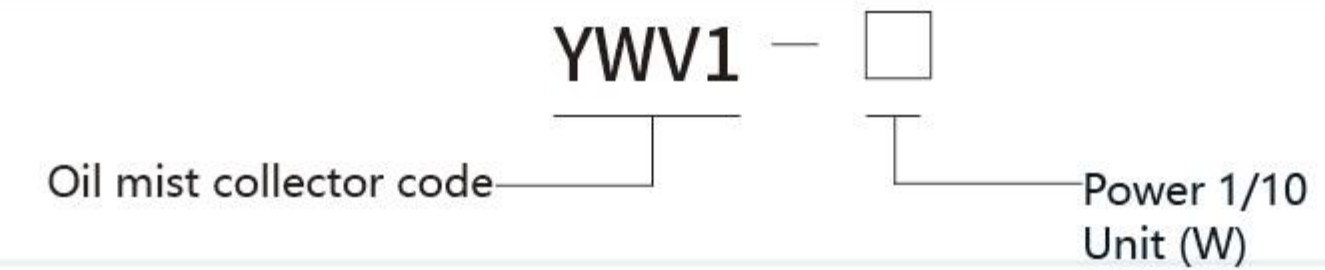

PRODUCT PARAMETERS

Model No.	Power supply	Power (kW)	Rotating speed (R.P.M)	Current (A)	Air Volume (m3/h)	Noise dB (A)	Efficiency (%)	Inlet Diameter (mm)	Diameter of Oil Return Port (mm)	Element Material	Dimensions (d×h)	Power Cord	Color
YWV1-18	3-phase, 220V/380V, 50Hz	0.18	2800	0.92/0.53	400	66±2	99	100	16	Synthetic Fiber	260×388	4芯	RAL9010(Customizable)
YWV1-37	3-phase, 220V/380V, 50Hz	0.37	2800	3.04/1.76	600	66±2	99	100	16	Synthetic Fiber	300×526	4芯	RAL9010(Customizable)
YWV1-150	3-phase, 220V/380V, 50Hz	1.5	2840	5.77/3.33	1500	68±2	99	200	16	Synthetic Fiber	360×600	4芯	RAL9010(Customizable)

Note: Customers with special requirements for products support customization.

MODEL SELECTION METHOD

Recommended models are provided below based on typical applications and industry standards; final selection should be determined according to actual operating conditions.

	Oil Mist Models	Air Volume	Door openings and closings per minute, general value (times/minute)	Suitable for processing room volume(m³)
For fully enclosed machines	YWV1-18	400	4~10	0.5~1
	YWV1-37	600	4~10	1~2
	YWV1-150	1500	4~10	2~5
General Formula		Airflow = Volume*Opening Frequency*60		
	Oil Mist Models	Air Volume	Estimated air speed required to absorb oil mist, general value(m/s)	Suitable for the opening area of the processing room(m²)
For partially enclosed machines	YWV1-18	400	0.5<V<1	0.05~0.1
	YWV1-37	600	0.5<V<1	0.1~0.15
	YWV1-150	1500	0.5<V<1	0.15~1
General Formula		Open Area * Estimated Wind Speed * 3600		

CLOSED-ENDED TYPE CALCULATION METHOD

Q—Oil mist collector air volume, in cubic meters per hour (m³ / h);
W×D×H—The volume of the processing chamber cavity (length×width×height), unit is meter (m)
A—The number of air changes per minute in the processing room, in units of times per minute (times/min).

OPEN-ENDED TYPE CALCULATION METHOD

Q—Oil mist collector air volume, in cubic meters per hour (m³ / h);
A × B—Opening size of the processing chamber (length x width), in meters (m)
V—Oil mist suction is expected to require wind speed, the unit is meters per second (m/s), generally more than 0.5m/s

CONSUMABLES REPLACEMENT



COLLECTION METHODS

ELECTROSTATIC ADHERENCE,
RETURN OIL PIPE RETURN FLOW

FUNCTIONAL SPECIFICATION

Machining generates oil mist and coolant vapor that can affect operator health, reduce efficiency, and accelerate machine wear. An oil mist collector removes airborne contaminants, improving the working environment and extending equipment service life. Highly integrated, filter-free design reduces maintenance costs while effectively improving workshop air quality.



STRUCTURAL FEATURES

- Mainly for the collection and recovery of oil-based atomized particles in the machining industry.
- The electrostatic oil mist collector adheres the oil smoke to the collector by means of electrostatic collection to achieve the purpose of purifying the oil.
- All basic components and electrostatic modules can be used again after cleaning, no disposable solid waste, low maintenance costs.
- Oil mist and oil smoke particles are mechanically separated through the honeycomb metal mesh, and smaller oil mist and particles are purified by the electrostatic module.
- The equipment is stable and accessible, in line with industry standard JB/T 12907-2016.
- Compact structure, easy to install, clean and maintain, improve the flexibility of the equipment.
- Low nest sound design $\leq 72\text{db(a)}$, improve the quality of the workshop working environment.

USE ADVANTAGE

- Efficient purification: The electrostatic oil mist collector can efficiently remove oil mist particles with a size of 0.1-0.01 microns, with a purification efficiency of over 98%.
- Reduce industrial accidents: oil mist deposition makes the working area, floor, walkway slippery, easy to cause fall accidents.
- Low operating cost: the equipment does not need to replace the filter material, low operating cost, simple maintenance.
- Reduce damage to mechanical equipment: a large amount of oil mist generated by high-speed cutting is adsorb on equipment and workpieces for a long time, can be the cause of mechanical equipment and electrical system failure. It brings no small trouble to the maintenance of machinery and equipment, it also greatly reduces the processing accuracy of mechanical equipment.
- Reduce damage to the environment and waste of resources: if the oil mist gas is discharged to the outside, it will damage the environment and cause capital waste on the source.

PRODUCT PARAMETERS

Model number	Adaptive power supply	Fan Power (kW)	Handling air volume (m ³ /h)	Electrode form	Output voltage HV (kV)	Output voltage LY (kV)	Output current (mA)	Electrostatic power (W)	Processing efficiency	Suction air temperature	Suction diameter (mm)	Size/quantity of electric field	Dimensions L×W×H (mm)	Mounting Dimension L×W (mm)	Weight (kg)
YWJ1-15	220V 50HZ	0.15	600-800	Double high voltage wire board	12	6	20	300	≥98%	<80℃	150	340×361×360/1	664×488×480	535×285	45

YWJ1-15 SERIES

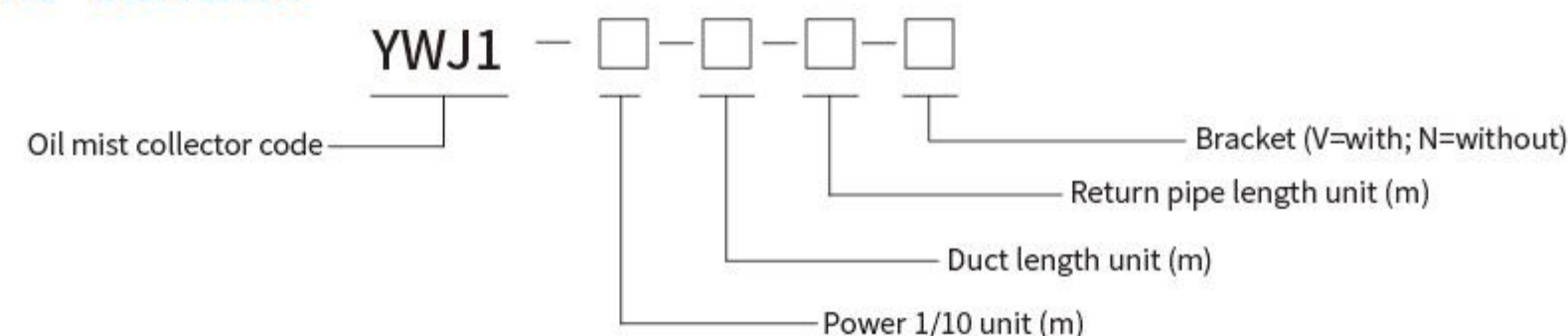

INTERPRETATION OF RESULTS

- The oil mist collector consists of a main body unit, electrical control box, pre-filter, and an integrated electrostatic field (high-voltage ionization with low-voltage collection).
- The main unit includes an integrated motor-impeller assembly and an oil drain valve.
- Modular design allows for efficient maintenance.

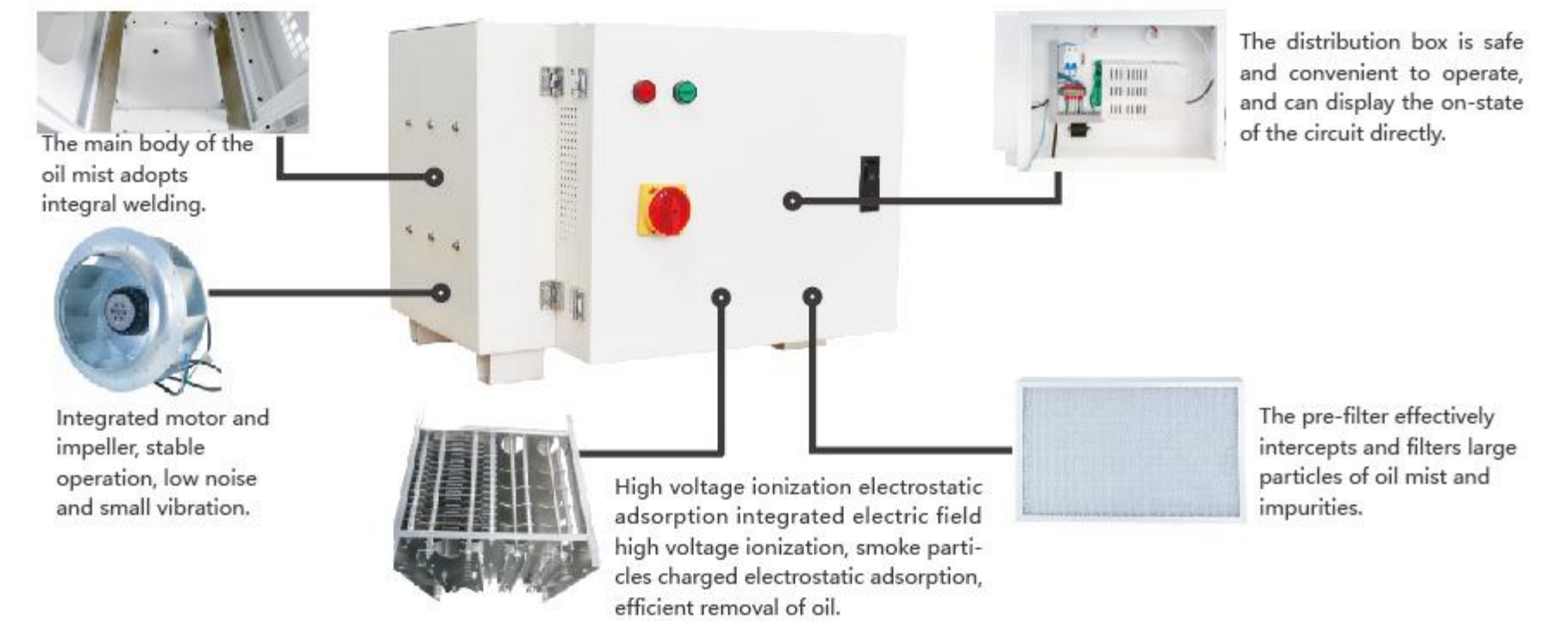

MOUNTING METHOD

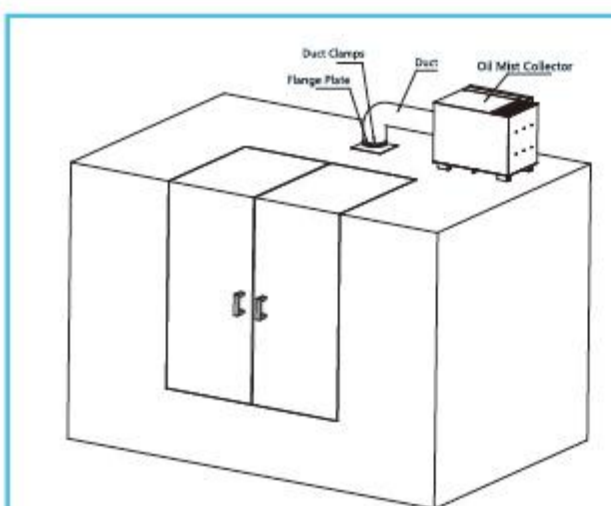

Top Mounting

- Prepare suction opening if not pre-installed.
- Mount main body unit on machine top and secure; install flange over opening.
- Connect flexible duct with hose clamp; avoid U-shaped routing.

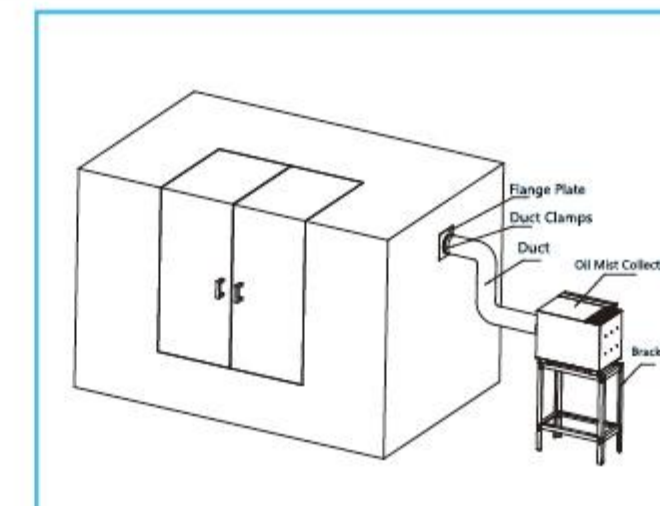

Side Mounting

- Prepare floor bracket and mounting holes according to installation dimensions.
- Place main body unit on bracket and secure; install flange to machine suction opening.
- Connect flexible duct with hose clamp; avoid U-shaped routing.

OPTIONAL ACCESSORIES



ELECTROSTATIC FIELD CLEANING PROCEDURE

- Switch off the main power supply.
- Discharge residual voltage using an insulated tool.
- Remove the electrostatic unit.
- Prepare a cleaning solution (approx. 60 ° C water with caustic soda at 50:1, or a dedicated cleaner).
- Immerse the unit for about 20 minutes.
- Rinse with a low-pressure water jet to remove oil residues, then allow to dry completely.
- Reinstall the unit and close the electrical cabinet.

Note:

- Do not alter the spacing between plates.
- Ensure the unit is completely dry before reinstallation (air-dry ≥ 20 hours until no moisture remains).